



Rolling & Wardrobe Doors

Rolling Doors

For over 50 years the Stylmark rolling door has been recognized as the finest in the industry. These doors move effortlessly at the touch of a finger, while adding security to your showcases. They feature anti-jump, security rolling hardware, which engages the door bottom to flanges on the track and prohibits removal of the door when it is locked.

Wardrobe Doors

Wardrobe Doors from Stylmark are designed to give years of trouble free service. Wheel assemblies are incorporated into the bottom rail, providing a smooth-rolling, long-lasting unit. Additional features include cantilevered rollers to easily accommodate out-of-plumb field conditions and optional security door styles to provide additional protection.

MerchLock™

Stylmark's MerchLock™ secure door system is the ideal addition for safeguarding products on your existing shelves. With a variety of door panel choices and a wide range of anodized finish options, Stylmark ensures seamless integration with your decor.

| | |
|----------------|--------------------|
| Rolling Doors | 2 |
| Wardrobe Doors | 16 |
| MerchLock™ | 18 |

Rolling Doors

Fully framed security rolling doors are a standard component of the Stylmark aluminum showcase system. Our industry leading doors feature anti-jump security rolling hardware, which engages the door bottom to the flanges on the track. This retainer also prohibits removal of the door while it is locked. Stylmark rolling door hardware and components are available in 12' stock lengths or may be custom fabricated to your specified lengths and requirements.

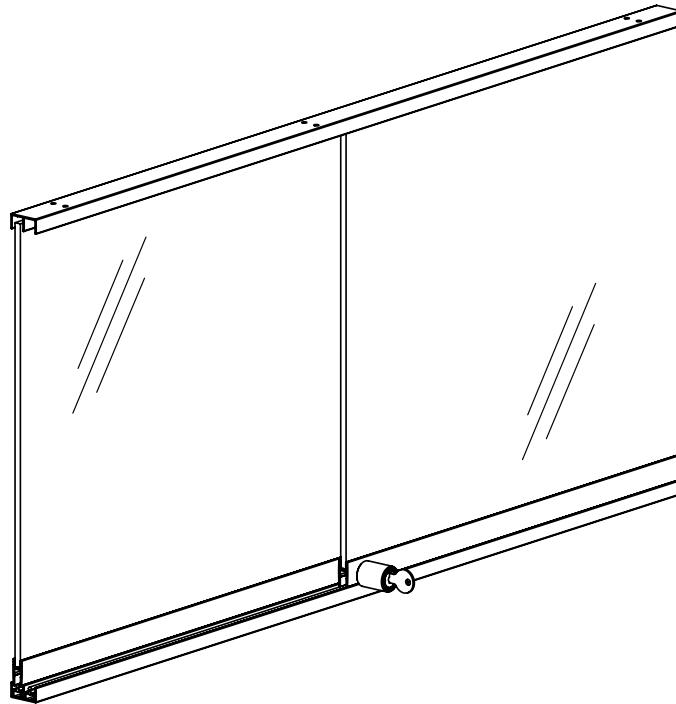

Ordering Rolling Doors

| Model # | Refer to pages 2-14 of this brochure |
|-----------------------|--|
| Number of Door Panels | For Assemblies Over 63" Wide, Four Doors with a Center Mullion are Recommended |
| Lock Condition | Kenstan, Plunger Lock or Fabricated for Best Lock |
| Opening Size | Width x Height (Door verticals are required on doors over 36" in height) |

- Notes:**
- When ordering rolling door hardware for clipped or curved showcases, please provide shop drawings.
 - Rolling door cabinet hardware can be ordered in stock length material for customer fabrication.
 - Lock and vinyl are sold separately when 12' assemblies are ordered.
 - Door verticals are required on doors over 36" high.

Rolling Doors - Fabricated & Shipped Knocked Down

Rolling doors maybe purchased as knock-down, prefabricated kit of parts (glass / panels not included) or as a kit of stocked length (12') finished extrusion and components.

Model Components

| Rolling Door Model # | Top Channel | Door Top | Door Bottom | Wheels & Retainers | Bottom Track | Includes: | | | |
|----------------------|------------------|------------------|------------------|--------------------|----------------------------|----------------------|-----------|----------|-----------|
| | | | | | | Wheels | Retainers | Jams | Verticals |
| 610005-01 | 110007 | 419007 | 110012 | 510001 | 110007 110009 | 8 | 8 | No | N/A |
| 610007-01 | 110007 | 419007 | 110012 | 510001 | 110019 | 8 | 8 | No | N/A |
| 610060-01 | 110080 | N/A | N/A | 510041 | 110079 | 8 | 8 | N/A | N/A |
| 610099-01 | 110007 | 419007 | 110012 | 510001 | 110078 | 8 | 8 | N/A | N/A |
| 610143-01 | 110008 | 419030 | 110012 | 510001 410444 | 110178 | TBD at time of order | | Optional | |
| 610144-01 | 110071 | 419030 | 110012 | 510001 410444 | 110178 | TBD at time of order | | Optional | |
| 610145-01 | 110102 | 419030 | 110012 | 510001 410444 | 110178 | TBD at time of order | | Optional | |
| 610146-01 | 110162 | N/A | N/A | 510041 410454 | 110208 | 8 | 8 | N/A | N/A |
| 610165-01 | 110022 110372 | 419007 | 110140 | 510041 | 110009 110022 110372 | 6 | No | Optional | |
| 610183-01 | 110102 | 419030 | 110412 | 510041 410381 | 110178 | TBD at time of order | | Optional | |
| 610184-01 | 110071 | 419030 | 110412 | 510041 410381 | 110178 | TBD at time of order | | Optional | |
| 610185-01 | 110008 | 419030 | 110412 | 510041 410381 | 110178 | TBD at time of order | | Optional | |
| 610187-01 | 110008 | 110024 419030 | 110140 510241 | 510041 410381 | 110178 | 8 | 8 | Yes | Yes |
| 610188-01 | 110071 | 110024 | 110140 | 510041 410381 | 110178 | TBD at time of order | | Optional | |
| 610189-01 | 110102 | 110024 | 110140 | 510041 410381 | 110178 | TBD at time of order | | Optional | |
| 610190-01 | 110008 | 110024 419030 | 110350 510331 | 510041 410381 | 110178 | 8 | 8 | Yes | Yes |
| 610191-01 | 110071 | 419030 | 110350 | 510041 410381 | 110178 | TBD at time of order | | Optional | |
| 610192-01 | 110102 | 419030 | 110350 | 510041 410381 | 110178 | TBD at time of order | | Optional | |

Notes: • Model # -01 indicates that components are fabricated prior to shipping per customer's dimensions
• Model # -02 indicates that components are shipped as 12' lengths

Rolling Doors - Stock Length

Model Components

(Lock and vinyl are sold separately when 12' assemblies are ordered)

| Stock Length Rolling Door Model # | Top Channel | Door Top | Door Bottom | Wheels & Retainers | Bottom Track | Includes: | | | |
|---|-------------|------------------|------------------|-----------------------|------------------|-----------|-----------|------|-----------|
| | | | | | | Wheels | Retainers | Jams | Verticals |
| 610005-02 | 110007 | 419007 | 110012 | 510001 | 110007 110009 | 8 | 8 | No | N/A |
| 610007-02 | 110007 | 419007 | 110012 | 510001 | 110019 | 8 | 8 | No | N/A |
| 610060-02 | 110080 | N/A | N/A | 510041 | 110079 | 8 | 8 | N/A | N/A |
| 610099-02 | 110007 | 419007 | 110012 | 510001 | 110078 | 8 | 8 | N/A | N/A |
| 610146-02 | 110162 | N/A | N/A | 510041 410454 | 110208 | 8 | 8 | N/A | N/A |
| 610187-02 | 110008 | 110024 419030 | 110140 510241 | 510041 410381 | 110178 | 8 | 8 | Yes | Yes |
| 610190-02 | 110008 | 110024 419030 | 110350 510331 | 510041 410381 | 110178 | 8 | 8 | Yes | Yes |

- Notes:
- Model # -01 indicates that components are fabricated prior to shipping per customer's dimensions
 - Model # -02 indicates that components are shipped as 12' lengths

Rolling Doors

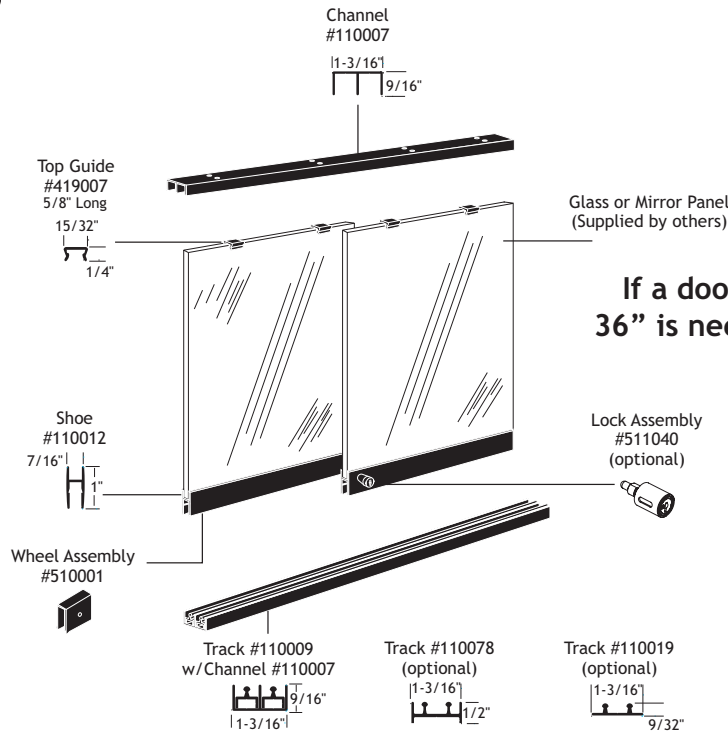

Model #610005-01*
Model #610005-02*
Standard assembly with removable track designed for easy cleaning

Model #610007-01
Model #610007-02
Economy assembly using one piece double track

Model #610099-01
Model #610099-02
Standard rolling door assembly

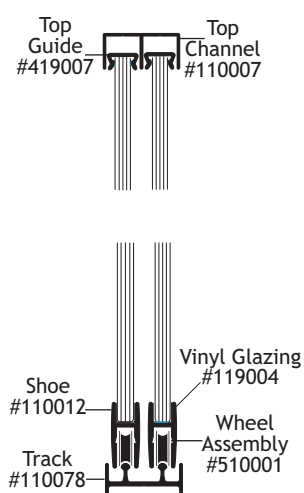
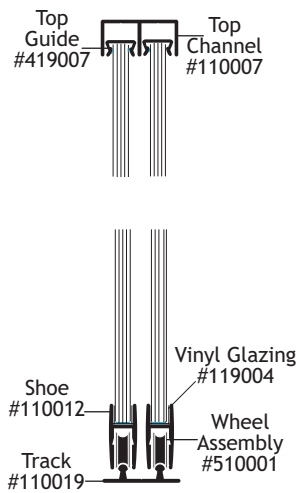
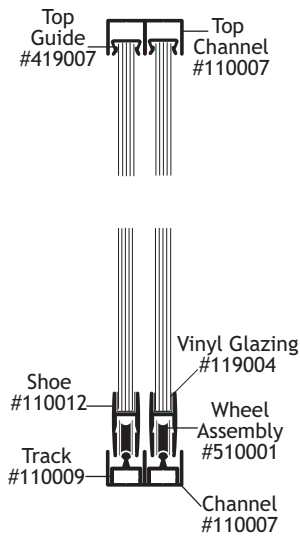

- Notes:**
- Model # -01 indicates that components are fabricated prior to shipping per customer's dimensions
 - Model # -02 indicates that components are shipped as 12' lengths
 - Model #610005 has several jamb options that would affect glass size.
- Please contact Stylmark Customer Care for assistance.

Rolling Doors

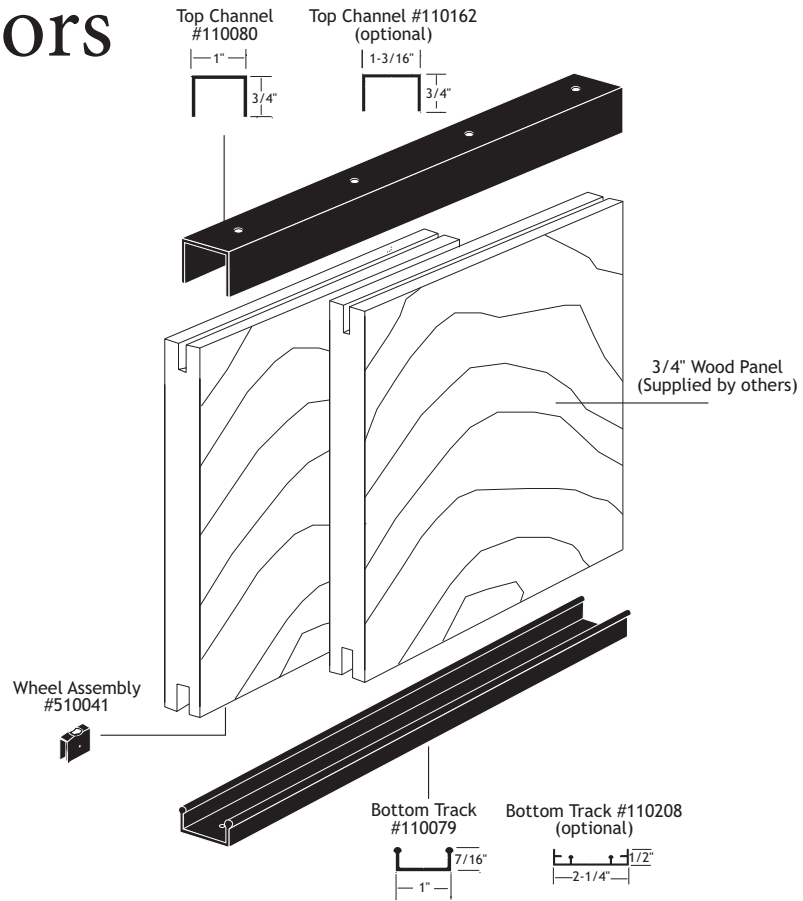

Model #610060-01
Model #610060-02
 Double track for use
 when security is not required

Model #610146-01
Model #610146-02
 Double track for use
 when security is required

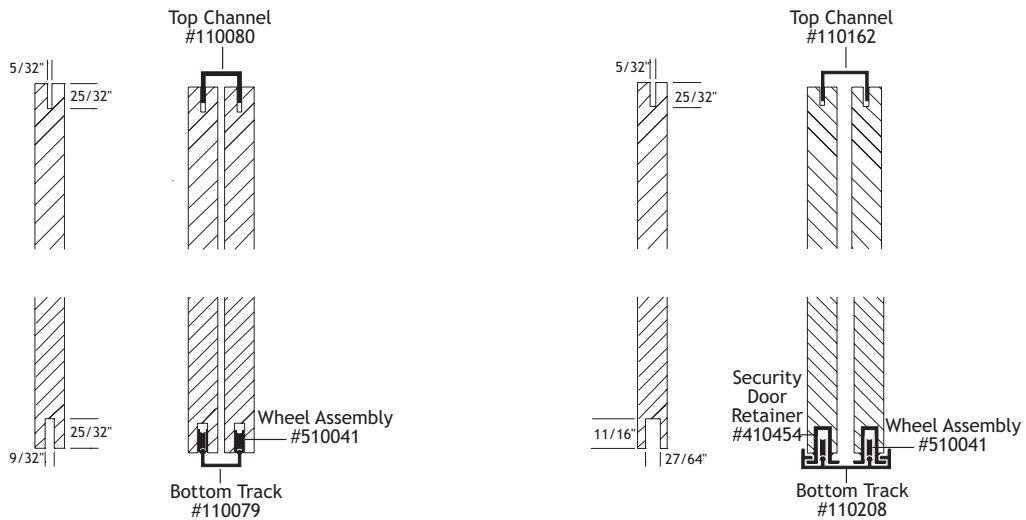

- Notes:
- Model # -01 indicates that components are fabricated prior to shipping per customer's dimensions
 - Model # -02 indicates that components are shipped as 12' lengths

Rolling Doors

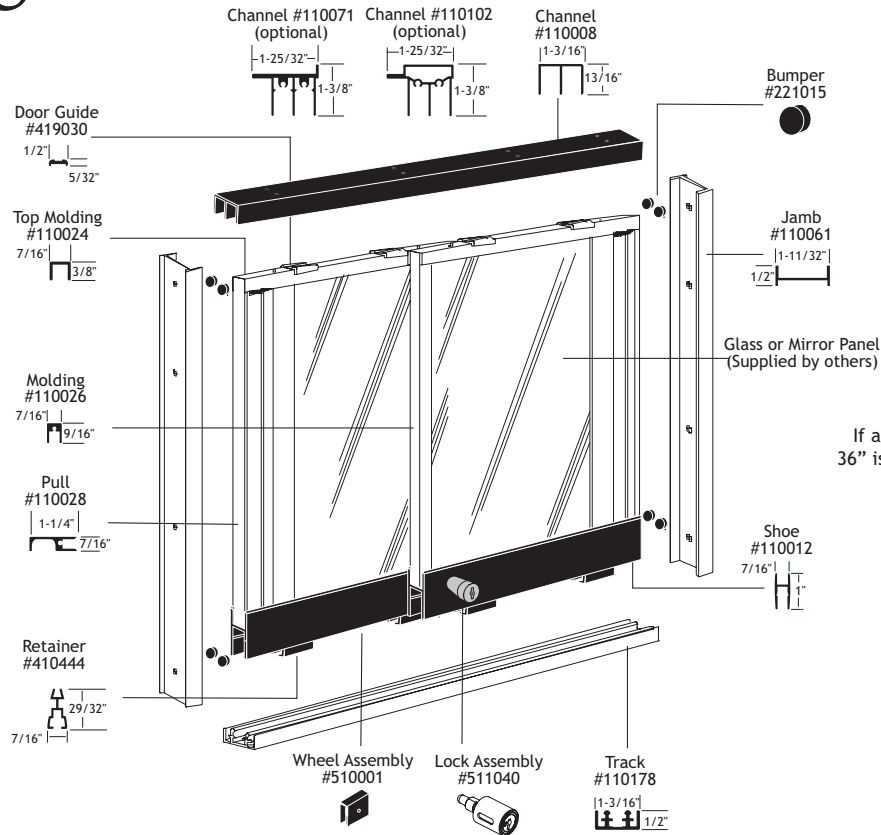

If a door height greater than 36" is needed, vertical moldings are required.

These security rolling door assemblies are for 1/4" panels up to 50 pounds.

Model #610143-01

Features the 110008 header and 110012 shoe. Optional door verticals and jambs are available.

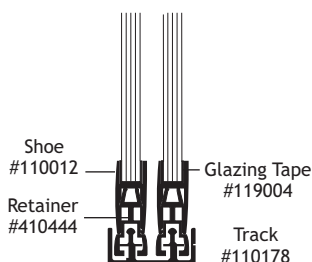
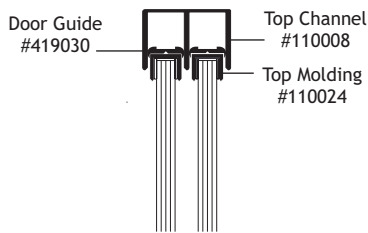

Model #610144-01

Features the 110071 top header (back frame) and 110012 shoe.

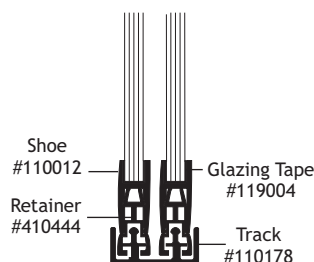
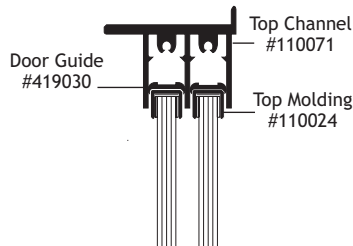

Model #610145-01

Features the 110102 top header (back frame) and 110012 shoe.

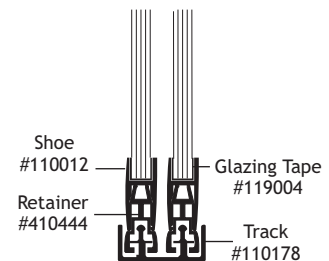
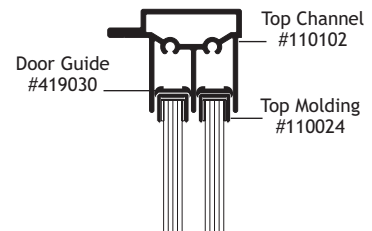

Notes: • Model # -01 indicates that components are fabricated prior to shipping per customer's dimensions

Rolling Doors

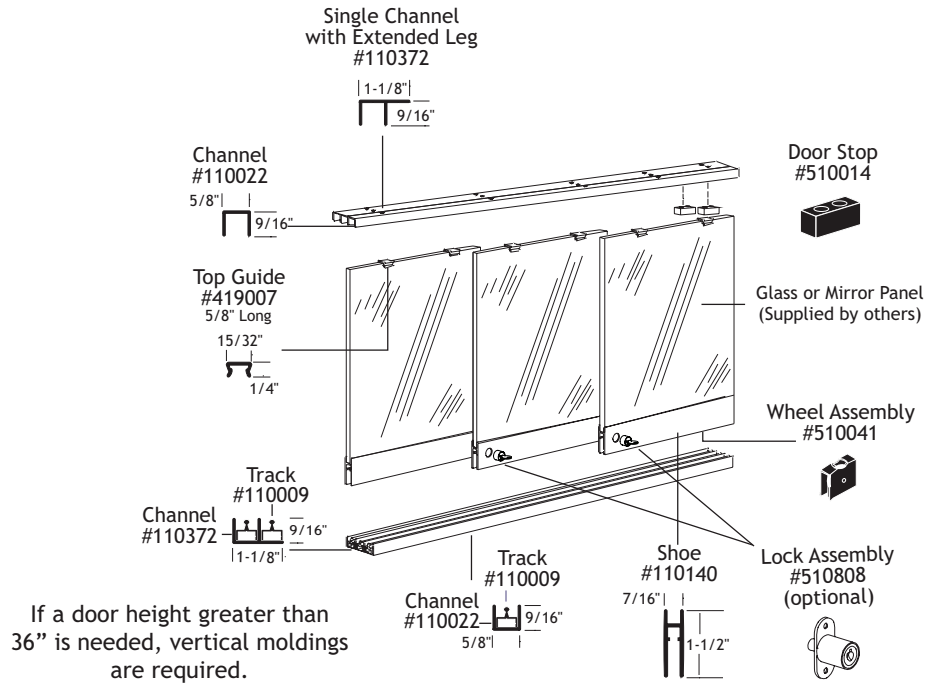

Model #610165-01

Multiple tracks allow maximum usage of opening by stacking the doors for open access.

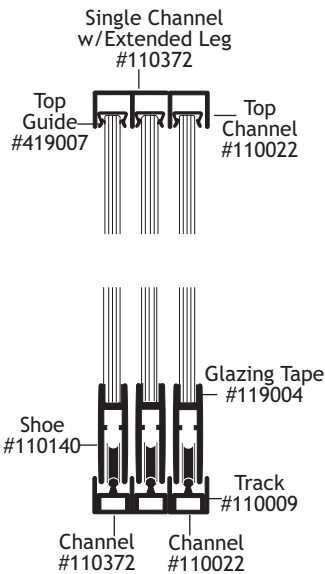

- Notes:
- Jambs and door verticals are available with fabricated assemblies.
 - Model # -01 indicates that components are fabricated prior to shipping per customer's dimensions

Rolling Doors

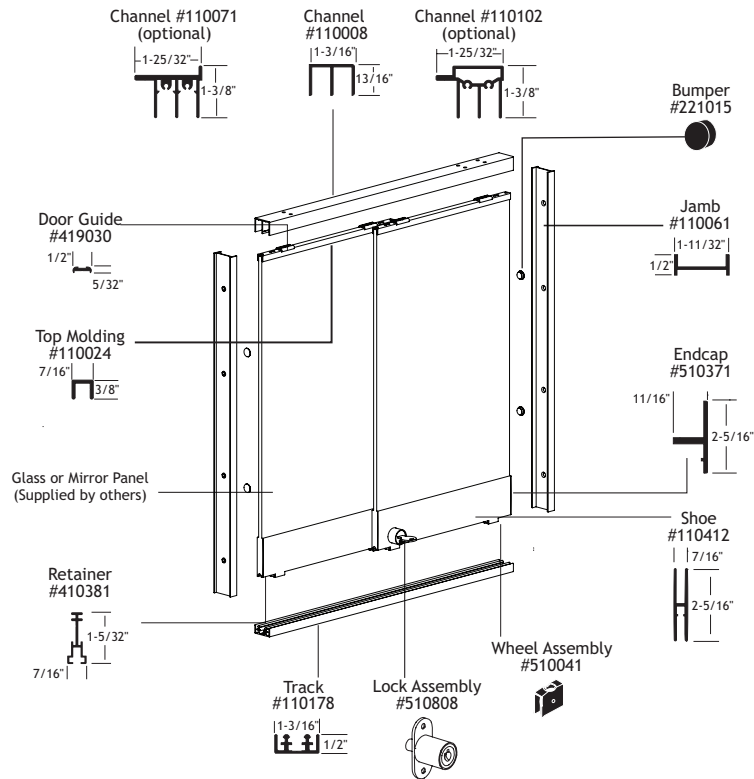

Model #610183-01
Features the 110412 shoe with 110102 top header (back frame).

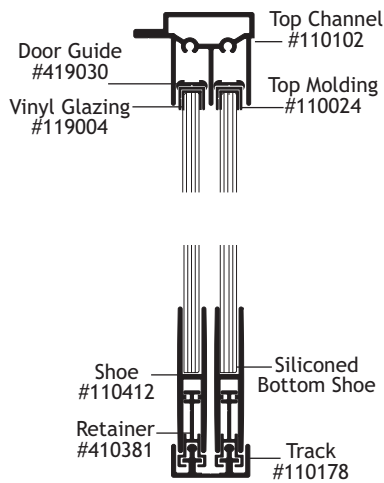

Model #610184-01
Features the 110412 shoe with 110071 top header (back frame).

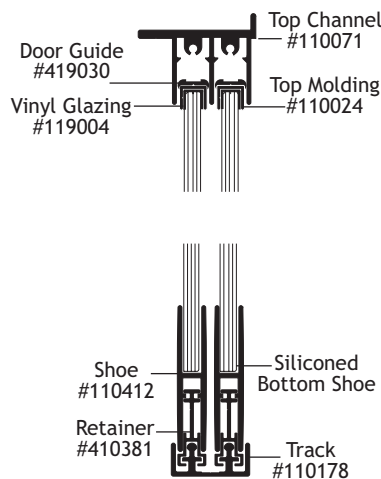

Model #610185-01
Features the 110412 shoe with 110008 top header (back frame).

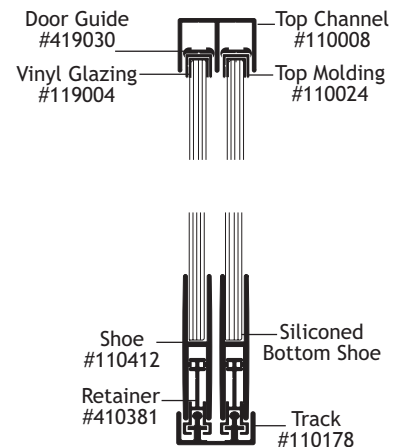

Notes: • Model # -01 indicates that components are fabricated prior to shipping per customer's dimensions

Rolling Doors

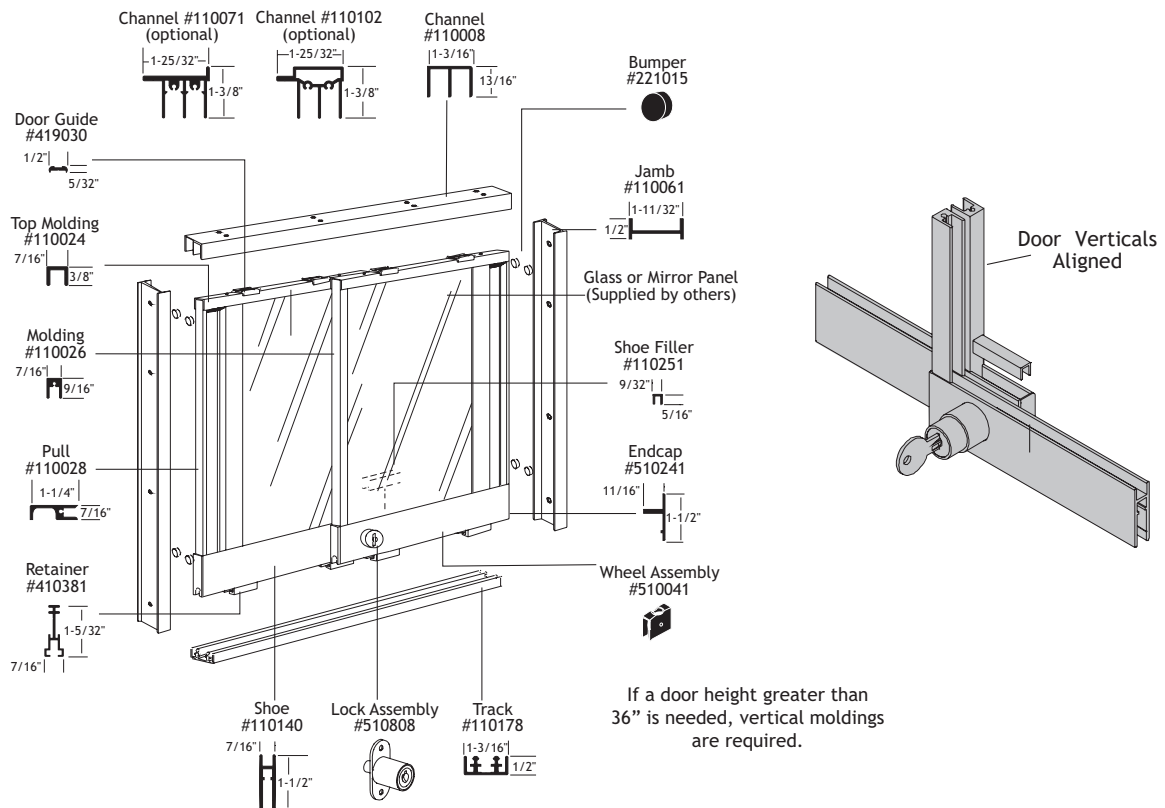

Security heavy duty rolling doors for 1/4" panels up to 80 pounds. Door verticals are standard, but you may order without. Assembly numbers 610187, 610188 and 610189 require overlapping doors to allow for alignment of door verticals. In this case, a shoe filler is used in the rear shoe. This overlap also enables glass for both front and rear doors to remain the same size (shown in picture inset).

Model #610187-01
Model #610187-02
 Features the 110008 top header and 110140 shoe.

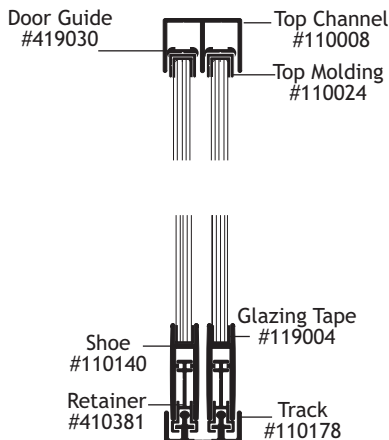

Model #610188-01
 Features the 110071 top header and 110140 shoe.

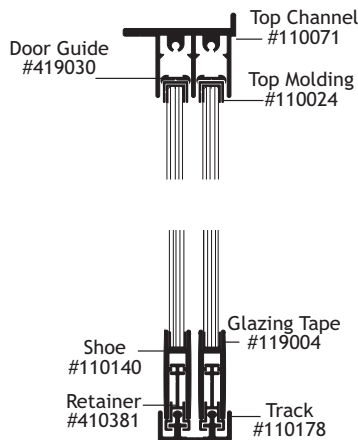

Model #610189-01
 Features the 110102 top header and 110140 shoe.

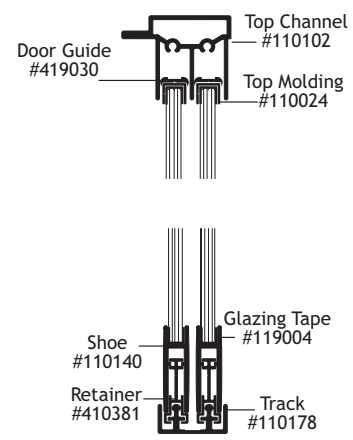

- Notes:
- Model # -01 indicates that components are fabricated prior to shipping per customer's dimensions
 - Model # -02 indicates that components are shipped as 12' lengths

Rolling Doors

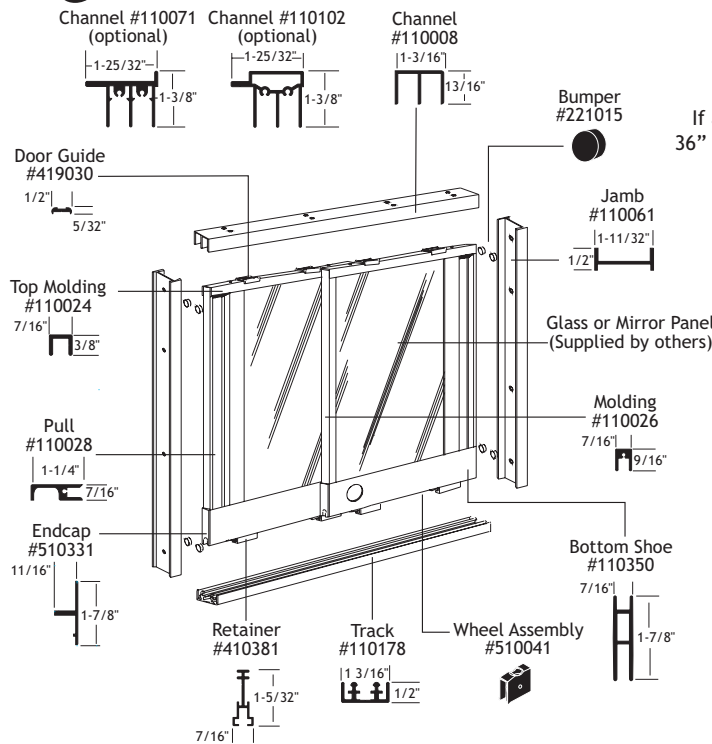

If a door height greater than 36" is needed, vertical moldings are required.

Note: Door verticals do not align

These assemblies feature the 110350 shoe, which accommodates the 4S Bestlock (supplied by others). Used for 1/4" panels up to 80 pounds. Door verticals are standard, but you may order without.

Model #610190-01
Model #610190-02
 Features the 110008 top header.

Model #610191-01
 Features the 110071 top header.

Model #610192-01
 Features the 110102 top header.

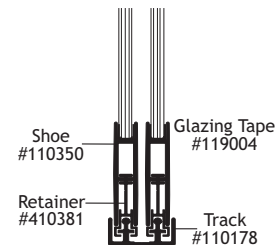
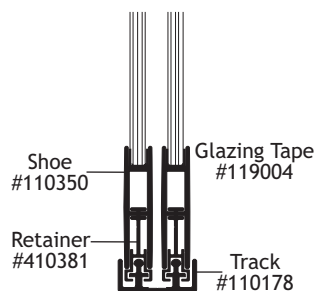
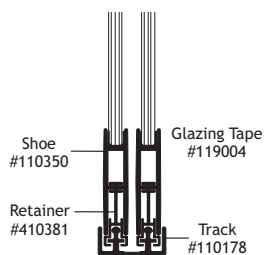
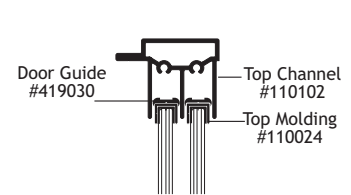
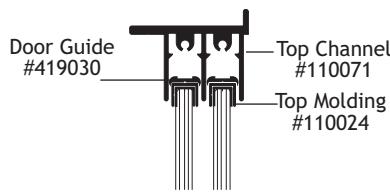
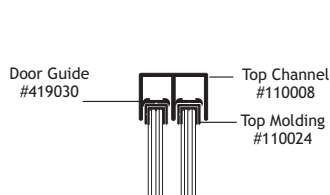

- Notes:
- Model # -01 indicates that components are fabricated prior to shipping per customer's dimensions
 - Model # -02 indicates that components are shipped as 12' lengths

Rolling Doors

Door Panel and Glass Sizing Chart

| Hardware Assembly Number | Width | | Height |
|--------------------------|--|--|----------------------------|
| | With Sides & Center Verticals Deduct from Opening Width and Divide by 2 | Without Sides & Center Verticals Add to Opening Width and Divide by 2 | Deduct from Overall Height |
| *610005 | 1-7/8" ④ | 1" ③ | 1-15/32" |
| 610007 | 1-7/8" ④ | 1" ③ | 1-7/32" |
| 610060 | - | 1" ③ | 45/64" |
| 610099 | 1-7/8" ④ | 1" ③ | 1-7/16" |
| 610143 | 2-9/16" ①④ | 5/16" ①③ | 1-27/32" |
| 610144 | 2-9/16" ①④ | 5/16" ①③ | 2-15/32" |
| 610145 | 2-9/16" ①④ | 5/16" ①③ | 2-15/32" |
| 610146 | - | 1" | 13/16" |
| 610165 | - | 4 (Divide by 3) ② | 1-15/16" |
| 610183 | - | 1-5/16" ①② | 2-15/16" |
| 610184 | - | 1-5/16" ①② | 2-15/16" |
| 610185 | - | 1-5/16" ①② | 2-5/16" |
| 610187 | 2-9/16" ①④ | 1-5/16" ①② | 2-5/16" |
| 610188 | 2-9/16" ①④ | 1-5/16" ①② | 2-15/16" |
| 610189 | 2-9/16" ①④ | 1-5/16" ①② | 2-15/16" |
| 610190 | 5/8" ⑤ | - | 2-11/16" |
| 610191 | 5/8" ⑤ | - | 3-5/16" |
| 610192 | 5/8" ⑤ | - | 3-5/16" |

Note: * Assembly 610005 has several jamb options that will affect glass size. Please contact Stylmark Customer Service for assistance.

- ① Jamb Included ② 2" Door Overlap ③ 1" Door Overlap
 ④ 9/16" Door Overlap ⑤ 2 1/2" Door Overlap

Door Jamb and Mullions

Stylmark's door jambs serve as a filler when spaces are not completely plumb and provide a vertical accent. Door mullions are typically used for header support and are recommended for spans of 63" or greater. They also serve as a divider and stop for multiple door applications.

Door Edge Molding and Pulls

When completely framed door panels are desired, door pulls and U-channel edge moldings are used, as shown.

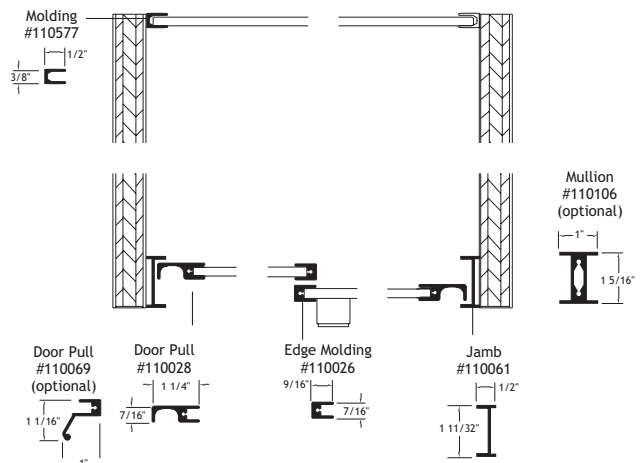

Rolling Doors

Hardware and Accessories

Part #110007

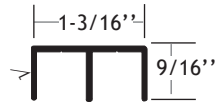

9/16"
Double Channel

Part #110008

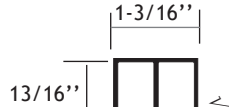

13/16"
Double Channel

Part #110009

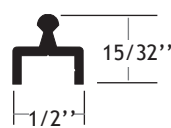

Drop In Track

Part #110012

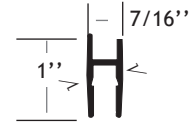

Shoe

Part #110014

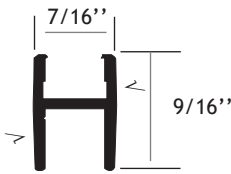

Glide Shoe

Part #110019

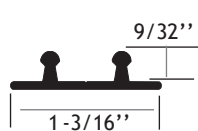

1-3/16"
Double Track

Part #110021

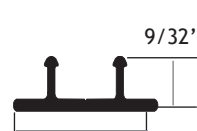

1-3/16"
Glide Track

Part #110022

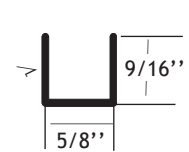

9/16" Single Channel

Part # 110023

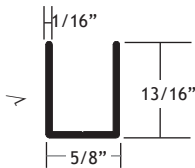

13/16" Single Channel

Part #110024

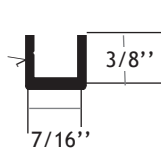

Edge Molding

Part #110026

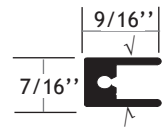

Edge Molding

Part #110027

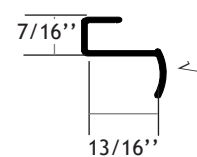

Door Pull

Part #110028

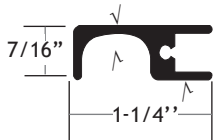

Flush Door Pull

Part #110029

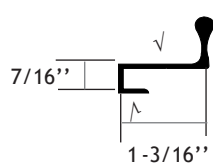

Door Pull

Part #110035



Slide Track

Part #110036

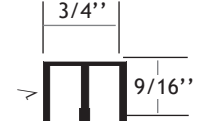

Slide Double Channel

Part #110061

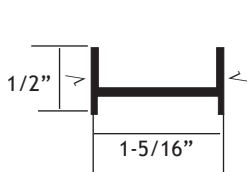

Jamb

Part #110063

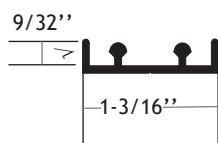

Double Channel Track

Part #110065

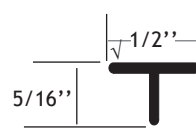

Anti-Jump Strip

Notes: • Stock length shoes do not include lock fabrication. Lock hole fabricated by customer.

√ = finished surface
Drawings are not to scale

Rolling Doors

Hardware and Accessories

Part #110066

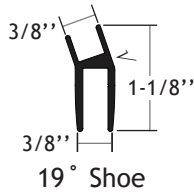

19° Shoe

Part #110067

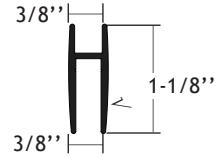

Part #110069

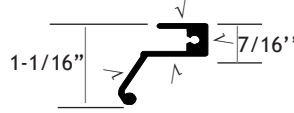

Door Pull

Part #110071

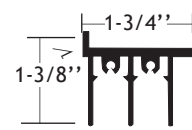

Part #110076

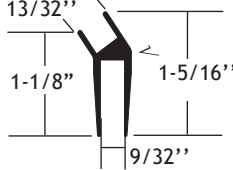

35° Deep Shoe

Part #110078

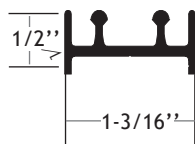

Channel Track

Part #110079

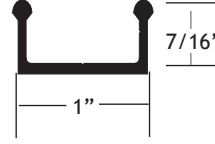

Wood Door Track

Part #110080

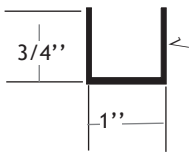

Top U Channel

Part #110102

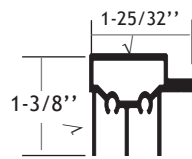

Top Rear Showcase Channel

Part #110106

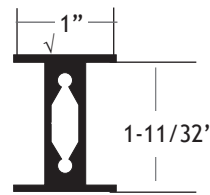

Mullion

Part #110140

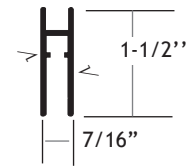

Heavy Duty Shoe

Part #110162

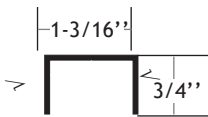

1 13/16"
Top Channel

Part #110178

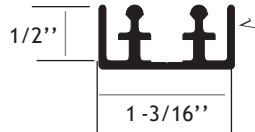

Security Track

Part #110208

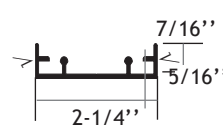

Security Track

Part #110251

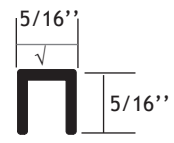

Shoe Filler

Part #110350

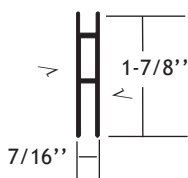

Heavy Duty Shoe

Part #110372

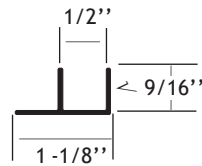

Single Channel with Extended Leg

Part #110412

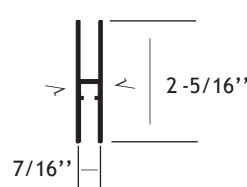

Deep Pocket Shoe

Notes: • Stock length shoes do not include lock fabrication. Lock hole fabricated by customer.

√ = finished surface
Drawings are not to scale

Rolling Doors

Hardware and Accessories

Part #119004



1/4" Black Vinyl Glazing Tape (250 ft)

Part #221014



Gray Bumper

Part #221015



Clear Bumper

Part #511178



Top Guide Assembly

Part #410381

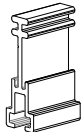

Security Door Retainer (use with 110140, 110350 or 110412 shoe)

Part #410444

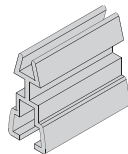

3/4" Security Door Retainer (use with 110012 shoe)

Part #410454

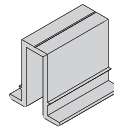

1-7/8" Security Door Retainer

Part #419007

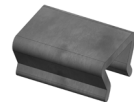

Top Guide

Part #419030



Vinyl Door Guide

Part #510001

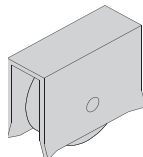

Wheel Assembly for 110012

Part #510006

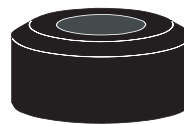

Door Bumper Assembly

Part #510014



1/2" Heavy Duty Door Stop Assembly

Part #510015

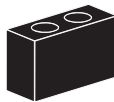

3/4" Heavy Duty Door Stop Assembly

Part #510041

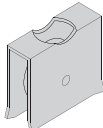

Heavy Duty Wheel Assembly

Part #510060

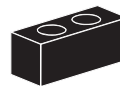

1/2" Heavy Duty Door Stop Assembly

Part #510241

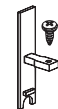

Endcap Assembly for 110140

Part #510331

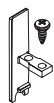

Endcap Assembly for 110350

Part #510371



Endcap Assembly for 110412

Part #511040

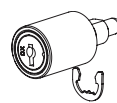

Chrome Plunger Lock Assembly

Part #510808

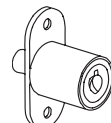

Chrome Plunger Lock Assembly

Notes: • Stock length shoes do not include lock fabrication. Lock hole fabricated by customer.

√ = finished surface
Drawings are not to scale

Wardrobe Doors

Wardrobe Doors from Stylmark are designed to give years of trouble free service. Wheel assemblies are incorporated into the bottom rail, providing a smooth rolling, long lasting unit. Additional features include cantilevered rollers to easily accommodate out-of-plumb field conditions and optional security door styles to provide additional protection.

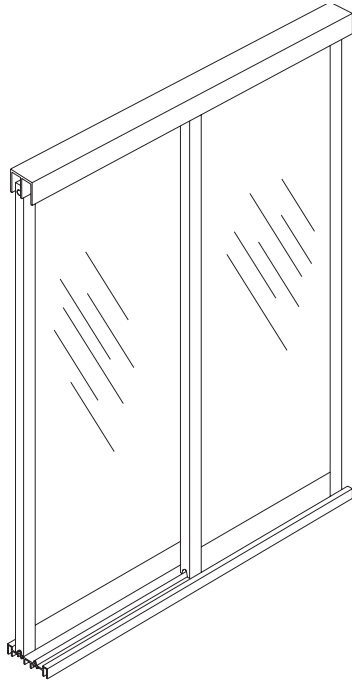

Cantilevered Rollers
 These wheels adjust easily to accommodate out-of-plumb field conditions and height variations plus 1 1/2" and minus 5/8"

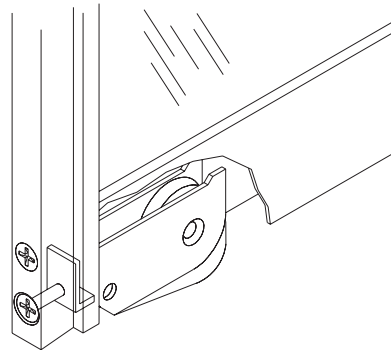

Ordering Wardrobe Doors

| Model | Description | Dimensions: Width x Height |
|--------|---------------------------|----------------------------|
| 630017 | 2 Door Conventional Style | Opening Size |
| 630019 | 2 Door Security Style | Opening Size |
| 630021 | 3 Door Conventional Style | Opening Size |
| 630022 | 3 Door Security Style | Opening Size |

- Notes:**
- Assemblies do not have a vertical jamb member.
 - The maximum weight per door must not exceed 125 pounds in weight, which is equivalent to a 5' x 8' door panel glazed with a 1/4" mirror.
 - Security style doors accept up to 1" diameter locks.
 - Panels provided by others.

Wardrobe Doors

Part # 130026
Conventional Door Stile

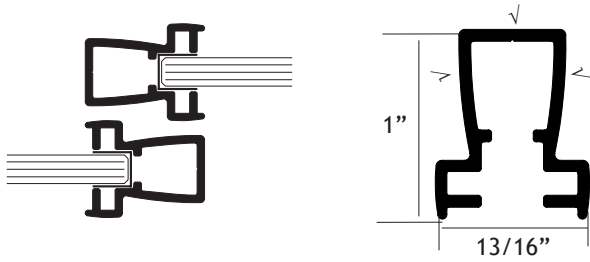

Part #130027
Security Door Stile

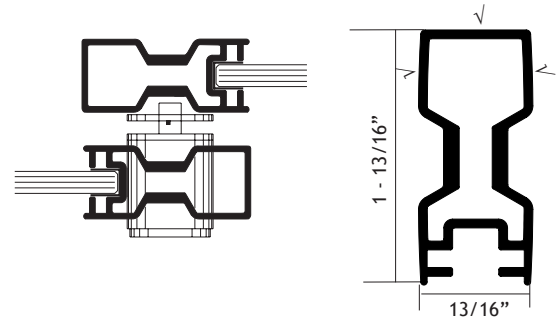

Part #130022
Wardrobe Door Header

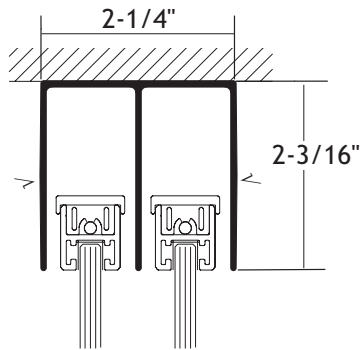

Part #130023
Wardrobe Door Track

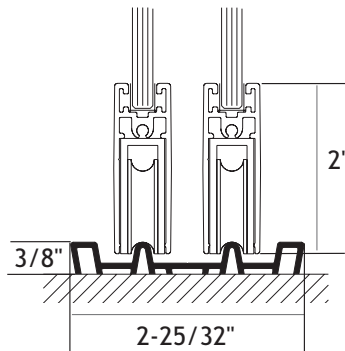

Part #139007
Glazing Vinyl for 1/4" Panels

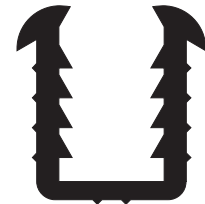

Part #530024
T-Bolt Plunger Lock Kit
(Kenstan PLD40T1 Polished Nickel
with two keys)

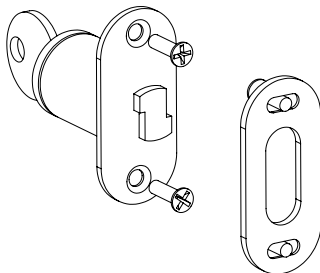

*** Hardware Accessory Kit**

| Part # | Description |
|--------|------------------------------------|
| 530012 | Hardware Kit, 2 Door Unit |
| 530023 | Hardware Kit, 3 Door Unit |
| 530026 | Hardware Kit, 2 Security Door Unit |
| 530027 | Hardware Kit, 3 Security Door Unit |

* Wardrobe door assemblies come complete with a hardware accessory kit that includes: Rubber bumpers, top guides, wheel assemblies and screws. Lock is included with all security door models.

√ = finished surface
Drawings are not to scale

MerchLock™

The MerchLock™ system by Stylmark offers superior security for retail environments, ensuring your assets are protected with robust, customizable rolling doors.

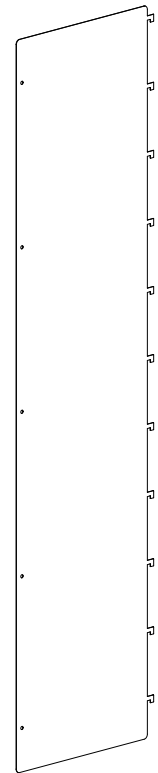
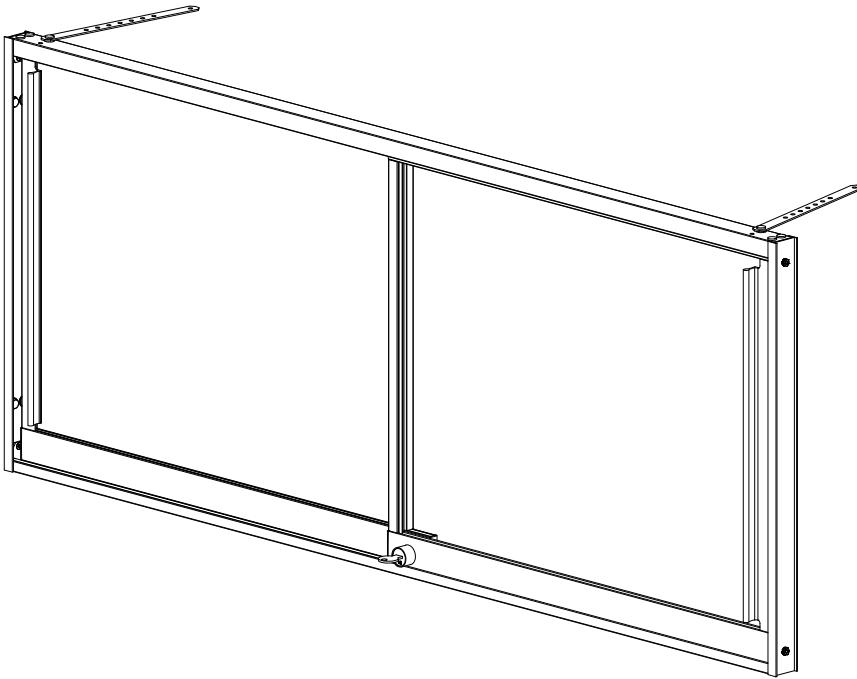

| Model | Door Verticals | Lock (optional) |
|--------|--------------------------------|--------------------------|
| 61034X | No | Located in door shoe |
| 61035X | Yes | Located in door shoe |
| 61036X | Yes, heavy duty at center door | Located in door vertical |

Last digit (X) represents door panel: 0 = glass, 1 = acrylic, 2 = HDPE

Enclosure Panel Kit
(sold separately)
511244-01 = white
511244-02 = black
(mounting hardware is included)

Key Features:

- **Enhanced Security:** Anti-jump hardware prevents door removal when locked.
- **Smooth Operation:** Effortless movement with the touch of a finger.
- **Versatility:** Ideal for retrofitting existing popular retail shelving fixtures.
- **Convenience:** Doors come fully assembled. Just mount the frame and insert the doors.
- **Door panel options:** Glass (clear), Acrylic (clear) or HDPE (white or black).

Applications:

Perfect for retail shelving, providing a sleek and secure solution to safeguard merchandise.