

**Figure 1**

## INSTALLATION INSTRUCTIONS

### *Before you begin*

These instructions illustrate the Stylmark® Rolling Door Assembly for Wood End Application (Models 610143, 610144 & 610145). If you have questions during assembly, call 800-328-2495 to reach technical assistance. This package does not include glass, wood screws or other door panels, which are necessary for complete assembly.

### *Tools you'll need*

- #2 Phillips screwdriver
- (2) Regular screwdrivers
- Scissors
- Rubber mallet
- Drill & bits
- #8 Wood screws (obtain locally)

**Please read these instructions carefully before beginning installation.**

# Stylmark Installation Instructions: Models 610143, 610144 & 610145

## Rolling Door Assembly – Wood End

### Getting Started:

These instructions are for pre-fabricated rolling door assemblies. If assembly was not ordered as pre-fabricated, the stock length extrusions will need to be fabricated by the installer to meet the required dimensions of the project.

### Step-by-Step Instructions

1. For model #610143, attach side jamb uprights to the wood end panel with #8 wood screws (obtain locally). **See Figure 2A.**
2. For models #610144 & 610145, attach side jambs to header then to the wood end panel with supplied screws (part #213016). **See Figure 2B.**
3. For model #610143, attach rolling door header to the underside of the wood case with #8 wood screws (obtain locally). **See Figure 3.**
4. Attach security track to the bottom of the wood case with #8 wood screws (obtain locally). **See Figure 4.**
5. Remove the adhesive backing from the rubber bumpers (part #221015) and attach them to side jambs uprights. **See Figure 5A** and onto the center mullion (installed if over 62"). **See Figure 5B.**
6. Assemble (do not install fasteners) the doorframe pieces. **See Figure 6.** Mark each piece for left or right door panel.
7. Cut lengths of black vinyl glazing tape to fit around the edges of the door panel. **See Figure 6.**
8. Fit the verticals onto the panel and tap into place with a rubber mallet. **See Figure 6.**
9. Fit top molding over the verticals and the door panel and tap into place with a rubber mallet. **See Figure 6.**
10. Fit the shoe onto the door panel and tap into place with a rubber mallet. **See Figure 7.**  
**Caution: Do not damage door retainers.**
11. Make sure the glazing materials fit evenly. Trim if necessary.
12. Attach the top molding and shoe to vertical pieces with #6 screws (part #213002). **See Figure 7.**
13. Repeat steps 6 through 12 for the other door panel.

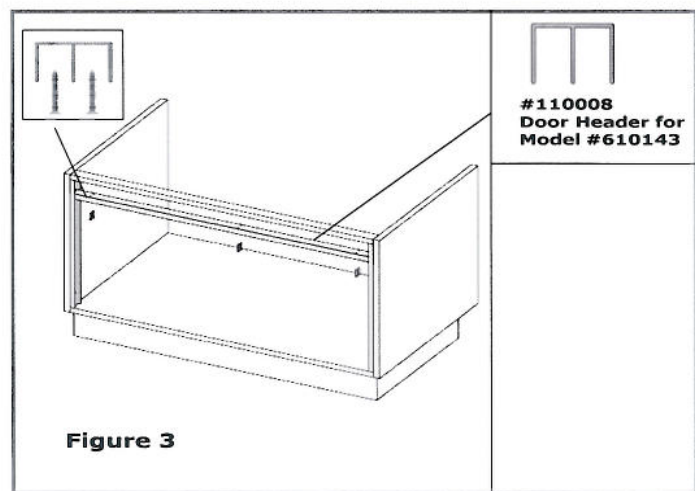
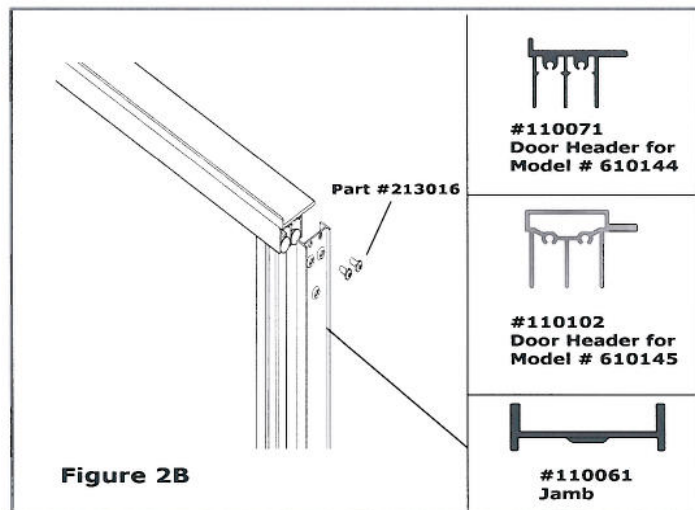
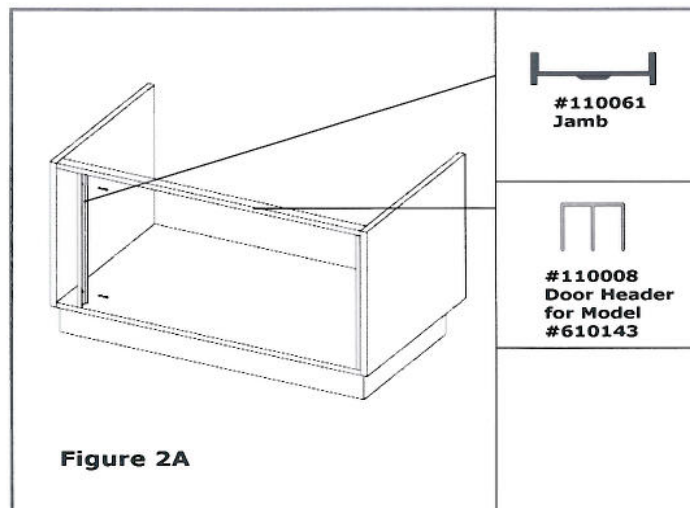

# Stylmark Installation Instructions: Models 610143, 610144 & 610145

## Rolling Door Assembly – Wood End

14. Insert the rear (left side) door panel into the rear header, top side first, above the notch in the security track. The notch is in the center of the security track. **See Figure 4.** Fit the shoe over the rear bottom track, and slide the panel to the left. If security track was ordered as non-fabricated, it will need to be notched to meet the required dimension of the project. Part #915078, security track punch, can be order separately if needed.
15. Insert the front (right side) door panel into the front header, top side first, above the notch in the security track. Fit the shoe over the rear bottom track, and slide the panel to the right.
16. If you need to remove the door panels, slide the panel to the notch in the security track, push the panel up, and pull the lower edge out toward you.

