

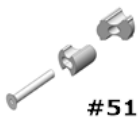

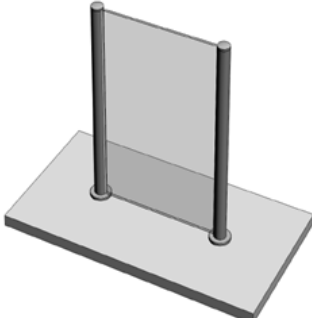

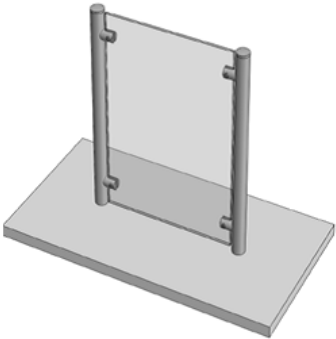
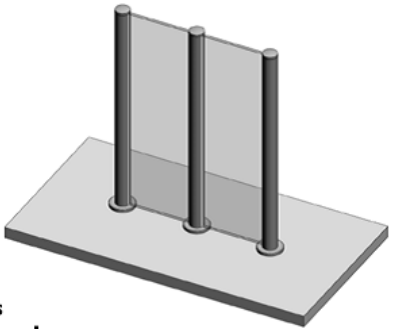

Installation Instructions

Café Series Partition Hardware

 <p>#511069 Clamp Mounting Kit</p>	 <p>Cafe Series Glass Channel Single Pane System</p>  <p>Cafe Series Glass Clamp System</p>  <p>Cafe Series Glass Channel Multi Pane System</p>
 <p>#511070 Channel Mounting Kit</p>	
 <p>#310614 End Cap</p>	
 <p>#511085 End Cap with Insert</p>	
 <p>#511079 Fixed Vertical Bracket Kit</p>	

INSTALLATION INSTRUCTIONS

Before you begin

These instructions illustrate the Stylmark® Café Series assemblies. If you have questions during assembly, call 800-328-2495 for technical assistance.

Please read these instructions carefully before beginning installation.

Stylmark Installation Instructions: Café Series Partition Hardware

#310614 - End Cap

Installation Instructions for Glass Channel Post:

1. Thread top of post approx. 1/2" (depth) using UNC Tap. **(See Figure 1)**
2. Chase and deburr hole.
3. Attach glass into glazing then drop glass & glazing into post. **(See Figure 1)**
4. Screw end cap to post.

Tools Needed:

- 5/16-18 UNC Tap
- Soft faced hammer

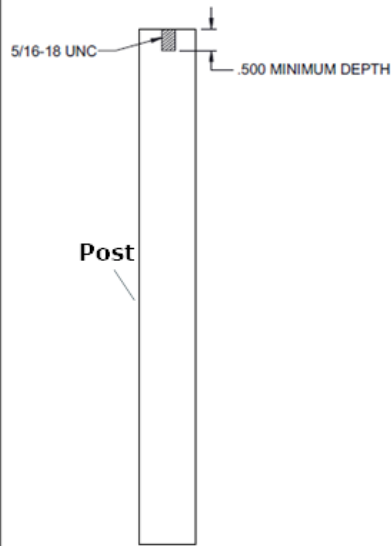

Figure 1

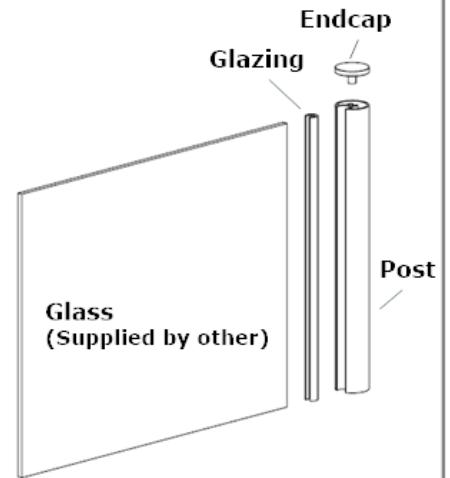

Figure 2

Stylmark Installation Instructions: Café Series Partition Hardware

#511069 - Glass Clamp Post Mounting Kit

Installation Instructions for Glass Clamp Post:

1. Determine location & identify the center of the post. **(See Figure 1)**
2. Drill mounting hole and countersink.
3. Place two fittings together and insert into bottom end of the post. Insert fasteners from bottom of mounting surface and tighten. Threadlock may be used to prevent loosening. **(See Figure 2)**

Tools Needed:

- Drill with .344" (11/32") drill bit
- Countersink tool
- 3/16" Hexagon socket wrench
- Medium strength threadlock

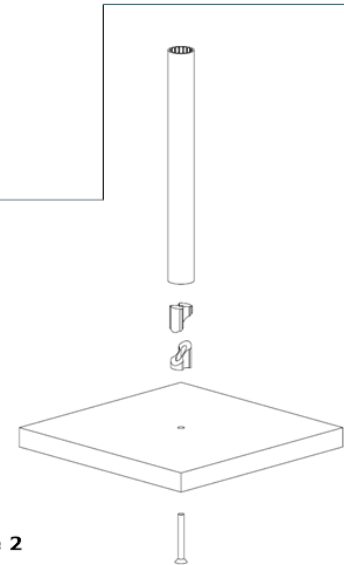
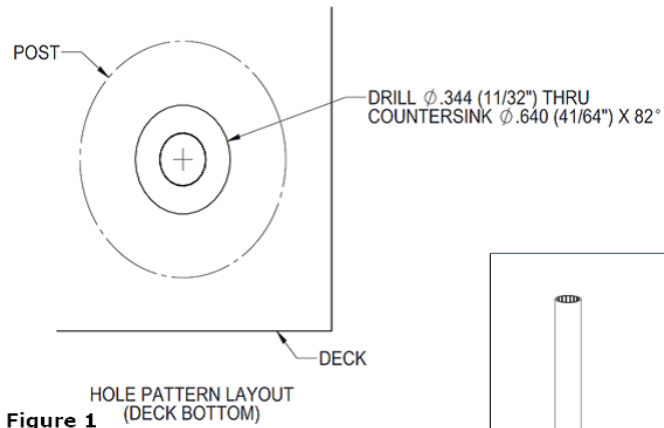

#511070 - Glass Channel Post Mounting Kit

Installation Instructions Glass Channel Post:

1. Determine location & identify the center of the post. Drill four holes per diagram. **(See Figure 1)**
2. Install fastener through the mounting plate and into the post. Threadlock may be applied to the fastener to prevent loosening. **(See Figure 2)**
3. Attach to the deck using four fasteners (obtain locally). Then slide cover plate over post to finish.

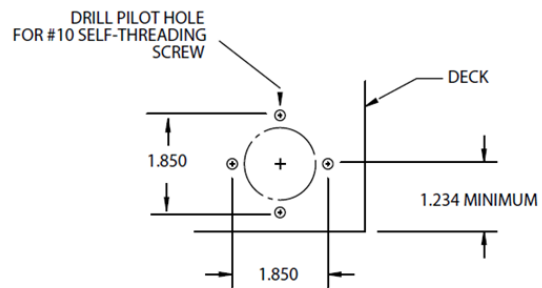

Tools Needed:

- Drill with bits
- #10 Flat head wood screws
- 3/16" Hexagon socket wrench
- Medium strength threadlock

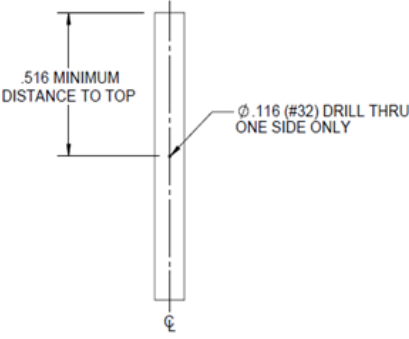
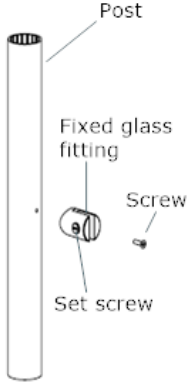

Stylmark Installation Instructions: Café Series Partition Hardware

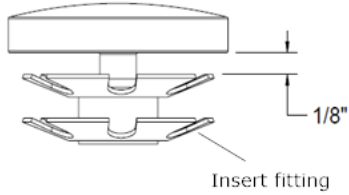
<p>#511079 - Fixed Vertical Bracket Kit</p> <p><u>Installation Instructions Fixed Vertical Bracket:</u></p> <ol style="list-style-type: none">1. Determine location of the fitting and identify the mounting hole location. (See Figure 1)2. Using a center punch, mark the hole location as determined. Drill mounting hole and deburr.3. Fasten fitting to the post using supplied fastener. (See Figure 2) Threadlock may be applied to the fastener to prevent loosening. Torque to approx. 18" - lbs max.4. Loosen set screw with screwdriver and install panel.5. Tighten set screw firmly to panel. <p><u>Tools Needed:</u></p> <ul style="list-style-type: none"><input type="checkbox"/> Drill with .116" (#32) drill bit<input type="checkbox"/> Center punch<input type="checkbox"/> Phillips #2 screwdriver<input type="checkbox"/> Slotted medium screwdriver<input type="checkbox"/> Tape measure<input type="checkbox"/> Medium strength threadlock	 <p>Figure 1</p>	 <p>Figure 2</p>
--	---	--

<p>#511085 - Endcap with Insert</p> <p><u>Installation Instructions Endcap with Insert:</u></p> <ol style="list-style-type: none">1. Thread insert fitting onto endcap. Allow a 1/8" gap between the fitting and underside of endcap. (See Figure 1)2. Using a soft faced hammer, firmly tap the endcap assembly into the post. Tighten endcap to post with hand. (See Figure 2) <p><u>Tools Needed:</u></p> <ul style="list-style-type: none"><input type="checkbox"/> Soft Face Hammer	 <p>Figure 1</p>	 <p>Figure 2</p>
--	---	--